

ASHLY

ASHLY AUDIO, INC.

# SC33 STEREO NOISE GATE



The Ashly SC-33 Stereo Noise Gate is a versatile two channel noise reduction system, requiring only 1¾" of rack space, designed to control leakage and background noise in recording and sound reinforcement applications. Acting much like a level-sensitive "switch", it automatically attenuates audio signals which fall below a user selected threshold, while passing audio that reaches or exceeds the threshold.

## FEATURES:

- Fast attack time (10  $\mu$ s)
- 60 dB threshold range
- Two-stage release circuit
- Stereo tie patch point for accurate tracking of two or more gates
- Inputs and outputs may be used balanced or unbalanced
- Extremely low noise and distortion
- In/out bypass switching
- Rugged 16 gauge steel chassis



The SC-33's operation can be broken down into two functional building blocks: a voltage controlled amplifier (VCA) which performs the actual task of muting or passing the audio signal, and a detector circuit which is responsible for providing the control voltage that determines the gain of the VCA.

Use of a VCA as a gain control element provides several advantages in a noise gate, including superior audio fidelity, accurate tracking of two or more units tied for stereo operation, and attack/release speeds much faster than those possible with optically coupled devices. The Ashly VCA used in the SC-33 is a Class-A device exhibiting extremely low distortion, low noise, low control voltage feedthrough (turn-on click), and excellent thermal stability.

The detector circuit encompasses all of the front-panel controls and generates a control voltage which gives the SC-33 its turn-on and turn-off characteristics. Through the use of unusually wide-range time constant options and a unique dual release-time circuit, a great variety of gating effects can be achieved. A very fast (10 microsecond) attack time insures that the leading edge of fast transient material such as snare drums will never be lost, and the fade control offers smooth, linear fade times of up to 30 seconds. The hold control offers a "wait before fading" option to prevent premature initiation of the fade cycle, useful when processing material that contains natural pauses, such as speech and instrumental solos. The threshold range is greater than 60 dB, making the SC-33 useful for both professional and semi-pro signal levels. Other thoughtful features include detector symmetry to within 1/4 dB, a hysteresis circuit to absolutely prevent chattering near threshold, high slew-rate circuitry throughout, active balanced inputs, and a 16 gauge steel chassis.

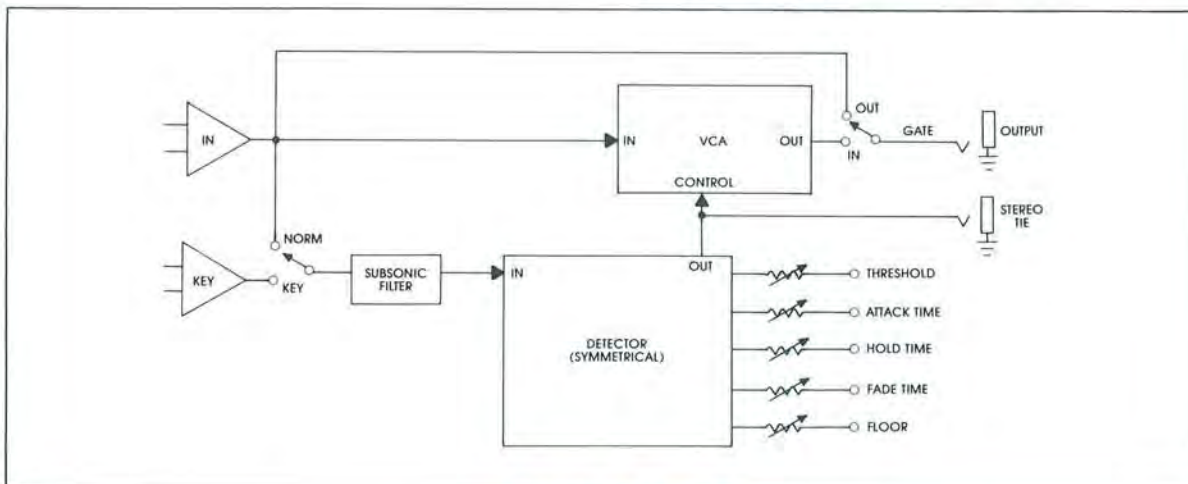

### SPECIFICATIONS:

**FREQUENCY RESPONSE** 5Hz to 100kHz, +0, -2 dB  
**THD, 20-20 kHz, +10 dBV**  
 Inputs .02%  
**IM Distortion, 20-20kHz, +10 dBV Input** .02%  
**Crosstalk from Key Input @ 1kHz** -85 dB  
**Noise, 20Hz-20kHz** -85 dBV  
**GAIN** Unity  
**DETECTOR SYMMETRY** ±0.25 dB  
**Control Voltage Feedthrough** -65 dBV typical  
**MAX INPUT/OUTPUT LEVEL** +20dBV  
**Slew Rate** > 10V per microsecond  
**Threshold Range** -40 dBV to +20 dBV

**Attack Time (per 40 dB gain increase)** 10 microseconds to 30 seconds  
**Hold Time** 40 milliseconds to 12 seconds  
**Fade Time (per 40 dB gain decrease)** 15 milliseconds to 30 seconds  
**Noise Attenuation (Floor)** 0 dB to 75 dB  
**Input Impedance** 10k Ω Balanced Bridging (Active)  
**Output Impedance** 100 Ω, terminate with 600 Ω or greater  
**ADDITIONAL FEATURES** Key Input, switch selectable  
 Noise Gate Bypass switch  
 Stereo interconnect via rear panel jacks  
 LED Threshold Indicator